

MVL-KF2524M-25MP

1.2" 25mm 25MP FA LENS

KF-P series FA Lens are optimized for machine vision light sources and sensors, with high resolution, excellent image uniformity, high transmittance and good stability. Featured with fixed focal length, manual aperture and compact size, it is suitable for machine vision industry



Key Features

- Ultra high resolution and consistency of image clarity
- 1.2" image circle, bigger aperture, lower distortion, higher illumination relative
- Achromatic optical system design, better imaging performance with color camera
- Maintain excellent optical properties at different object distances
- Excellent vibration resistance and stability at high and low temperature performance, optical axis shifting within pixel level
- Multilayer and broadband coating design, compatible with

Distortion

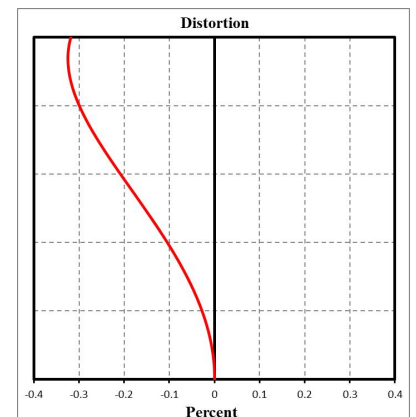

MTF

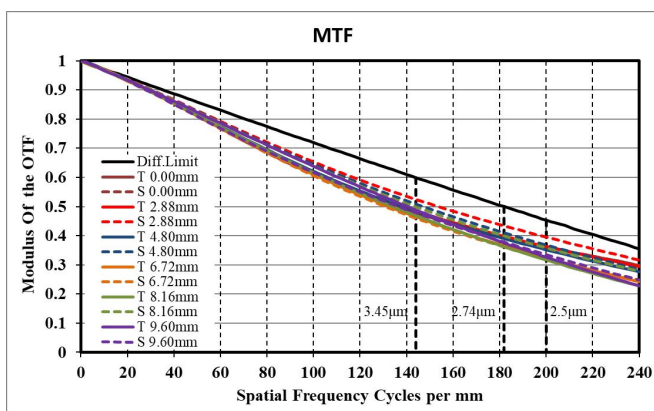

Relative Illumination

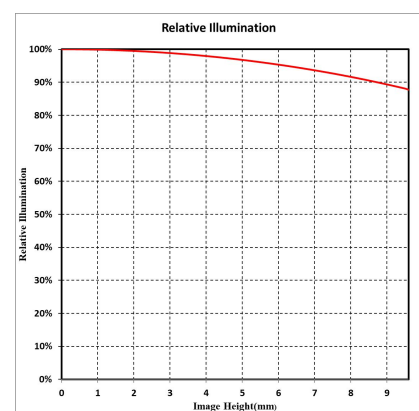

Note: The above curves are the simulate results based on F4, $\beta=-0.082$, WD=300 mm

Specification

	Model	MVL-KF2524M-25MP
Parameter	Fixed focal length, Manual iris, 25MP, FA Lens	
Performance		
Focal length	25 mm	
F-number	F2.4 to F16	
Image size	Ø19.3 mm (1.2")	
Distortion	-0.04%	
Minimum object distance	0.15 m	
Field of view	D (19.30 mm): 40.80° H (14.60 mm): 31.42° V (12.63 mm): 27.34°	
Mechanical		
Iris control	Manual	
Focus control	Manual	
Filter thread	M37 × 0.5	
Mount	C-mount	
Flange back length	17.526 mm	
Dimension	Ø40 × 58.4 mm (Ø1.57" × 2.3")	
Weight	163 g (0.359 lb.)	
Temperature	-10 °C to 50 °C (14 °F to 122 °F)	
General		
Certification	RoHS 2.0	

Dimension

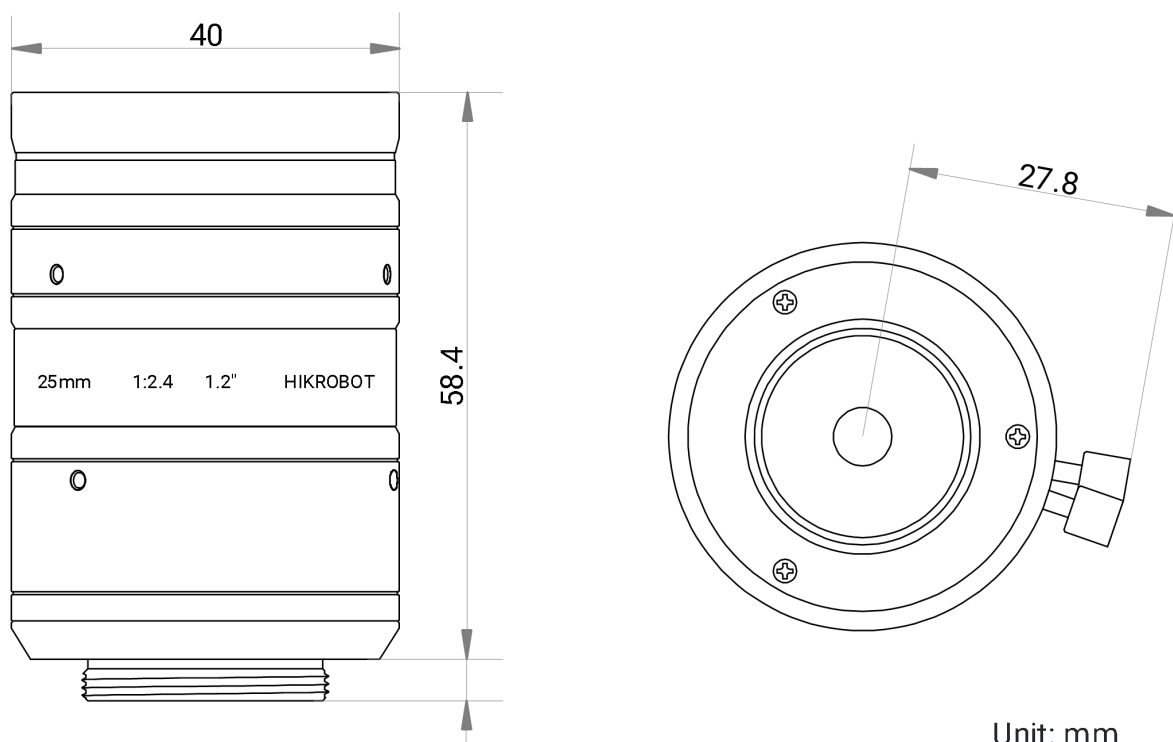

Unit: mm

Field of View

Extension (mm)	Working Distance (mm)		Magnification	Field of View (mm)					
				1.2"		1.1"		2/3"	
				H (14.6mm)	V (12.63mm)	H (14.14mm)	V (10.35mm)	H (8.45mm)	V (7.07mm)
2	near	99.84	-0.242	60.83	52.54	58.89	43.00	35.07	29.32
	far	216.93	-0.111	132.76	114.71	128.54	93.88	76.58	64.03
1	near	120.24	-0.203	72.39	62.55	70.09	51.20	41.77	34.93
	far	344.84	-0.071	207.70	179.54	201.12	146.99	119.92	100.29
0		150	-0.164	89.23	77.13	86.40	63.15	51.53	43.09
		200	-0.123	119.19	103.05	115.42	84.38	68.85	57.59
		250	-0.098	148.96	128.79	144.25	105.47	86.07	71.98
		300	-0.082	178.64	154.46	173.00	126.50	103.23	86.34
		350	-0.070	208.27	180.09	201.69	147.49	120.36	100.67
		400	-0.062	237.87	205.69	230.36	168.46	137.47	114.98
		450	-0.055	267.45	231.27	259.00	189.41	154.57	129.28
		500	-0.049	297.02	256.84	287.64	210.35	171.66	143.58
		550	-0.045	326.58	282.40	316.26	231.29	188.74	157.87
		600	-0.041	356.12	307.95	344.88	252.22	205.82	172.15
		650	-0.038	385.67	333.50	373.49	273.15	222.90	186.44
		700	-0.035	415.21	359.05	402.10	294.07	239.97	200.72
		800	-0.031	474.28	410.13	459.30	335.91	274.12	229.28
	900	-0.027	533.34	461.21	516.50	377.74	308.26	257.83	
	1000	-0.025	592.39	512.27	573.69	419.57	342.39	286.38	

HIKROBOT

Hangzhou Hikrobot Co. Ltd.
en.hikrobotics.com

© Hangzhou Hikrobot Co., Ltd. All Rights Reserved.

Hangzhou Hikrobot does not tolerate any infringement. Any organization or individual may not imitate or reproduce in whole or in part of the content. The data herein is based on Hikrobot's internal evaluation. Actual data may vary depending on specific configuration and operating condition. The information herein is subject to change without notice. All the content has been checked conscientiously. Nevertheless, Hikrobot shall not be liable to damages resulting from errors, inconsistencies or omissions.