

MV-SC3013XC

1.3 MP Color Vision Sensor



Introduction

With built-in high-precision vision algorithms, MV-SC3013XC vision sensor can realize counting, existence, measurement, recognition and other functions. It can be easily configured and operated via the SCMVS client software, and it uses RS-232 and Ethernet to output vision tool results and customized results.

Applicable Industry

Consumer electronics, food and pharmaceutical, automobile, etc.

Available Model

- 8 mm focal length: MV-SC3013XC-08M-WBN
- 12 mm focal length: MV-SC3013XC-12M-WBN
- 16 mm focal length: MV-SC3013XC-16M-WBN

Key Features

- Adopts embedded hardware platform to realize high-speed image processing.

- Built-in high-precision positioning, measurement and recognition algorithms for counting, defects, existence, positioning and other functions.
- Supports RS-232, TCP, UDP, FTP, Modbus, PROFINET, EtherNet/IP and other communication modes.
- Adopts multiple IO interfaces for input and output signals.
- Supports viewing the device's status in real time via 360° visual indicator, convenient for debugging and maintenance.
- Rotatable cable tail design, suitable for narrow space.
- Adopts polarized, diffused, and full-transparent multiple optical lighting with good environmental adaptability.
- IP67 protection without fear of harsh industrial application environments.

Specification

Model	MV-SC3013XC-08M-WBN	MV-SC3013XC-12M-WBN	MV-SC3013XC-16M-WBN
Tool			
Vision tool	<ul style="list-style-type: none"> ● Measurement: P2L measurement, contrast measurement, greyscale size, edge width measurement, width measurement, brightness analysis, L2L angle, color size, diameter measurement, line angle ● Existence: Anomaly detection, existence detection, spot existence, edge existence, contour existence, pattern existence, circle existence, line existence ● Count: Learning-based count, spot count, edge count, contour count, pattern count, color count ● Recognition: Category recognition, multi-object count, OCR, code recognition, color contrast, color recognition, classification registration, object detection registration ● Logic tool: Calculator, if module, logic judge, condition judge, string comparison, combination judge, formatting ● Defect detection: Exception detection ● Location: Match calibration, match location, position fixture ● Deep learning: DL classification, DL object detection 		
Solution capacity	Supports importing and exporting project, up to 32 projects can be stored		
Communication protocol	RS-232, TCP, UDP, FTP, PROFINET, Modbus, EtherNet/IP, MELSEC/SLMP, FINS, Keyence KV		
Camera			
Sensor type	CMOS, global shutter		
Pixel size	6.9 μm \times 6.9 μm		
Sensor size	1/1.45"		
Resolution	1216 \times 1024		
Max. frame rate	60 fps		
Dynamic range	77.8 dB		
SNR	43 dB		
Gain	0 dB to 15 dB		
Exposure time	6 μs to 1 sec		
Pixel format	RGB 8, Mono 8		
Mono/color	Color		
Electrical feature			
Data interface	Fast Ethernet (100 Mbit/s)		
Digital I/O	12-pin M12 connector provides power and I/O, including opto-isolated input (LINE 0/1/2) \times 3, opto-isolated output (LINE 3/4/5) \times 3, and RS-232 \times 1 Supports triggering device via pressing top trigger button		
Power supply	24 VDC		
Power consumption	Approx. 6.5 W @ 24 VDC		
Mechanical			
Lens mount	M12-mount, mechanical autofocus supported		
Focal length	8 mm (0.3")	12 mm (0.5")	16 mm (0.6")
Lens cap	Polarized + diffused + full-transparent lens cap		
Light source	White spot light source. Red/blue/IR point light source is optional		
Aiming system	Orange LED		
Indicator	360° visual indicator		
Dimension	Straight angle: 80.1 mm \times 43 mm \times 44.3 mm (3.2" \times 1.7" \times 1.7") Right angle: 58.5 mm \times 43 mm \times 65.4 mm (2.3" \times 1.7" \times 2.6")		
Weight	Approx. 190 g (0.4 lb.)		

Specification

Model	MV-SC3013XC-08M-WBN	MV-SC3013XC-12M-WBN	MV-SC3013XC-16M-WBN
Ingress protection	IP67 (under proper installation of waterproof lens cap)		
Temperature	Working temperature: 0 °C to 50 °C (32 °F to 122 °F) Storage temperature: -30 °C to 70 °C (-22 °F to 158 °F)		
Humidity	20% RH to 95% RH (no condensation)		
General			
Client software	SCMVS		
Certification	CE, KC		

Detection Range

Lens focal length	Installation distance	Field of View	Single Pixel Accuracy
8 mm	25 mm	27.6 mm × 22.08 mm	0.023 mm
	2000 mm	2208 mm × 1766.4 mm	1.82 mm
12 mm	60 mm	44.16 mm × 35.33 mm	0.036 mm
	2000 mm	1472 mm × 1177.6 mm	1.21 mm
16 mm	100 mm	55.2 mm × 44.16 mm	0.045 mm
	2000 mm	1104 mm × 883.2 mm	0.91 mm



Vertical FoV / mm

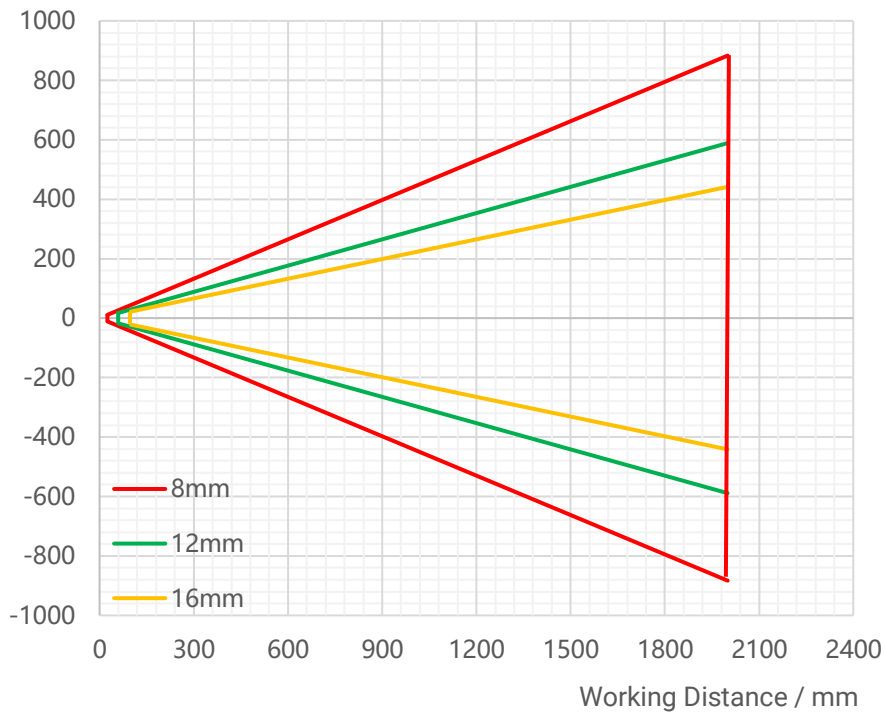

Dimension

Device (Straight Angle):

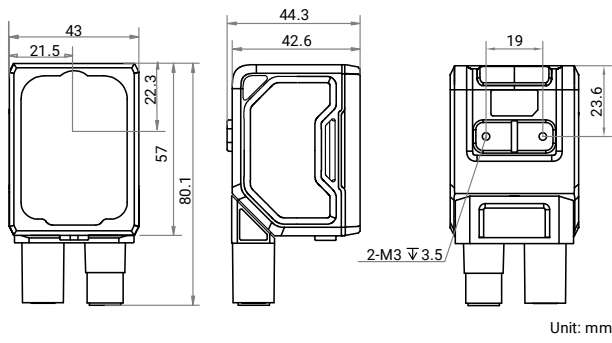

Device (Right Angle):

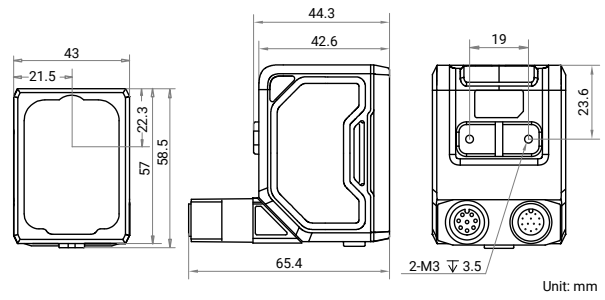

Device and Installation Bracket (Straight Angle):

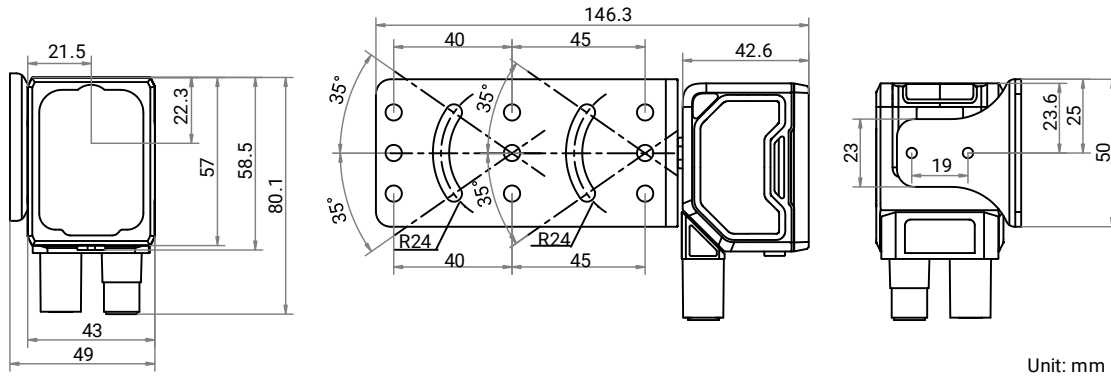

Device and Installation Bracket (Right Angle):

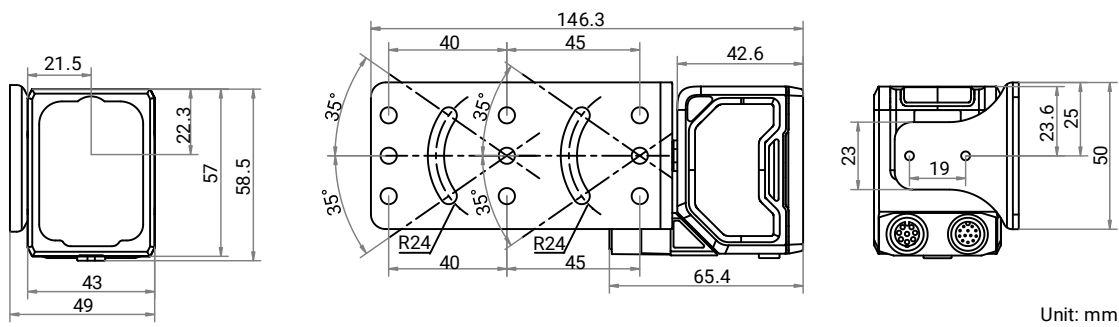

Installation Bracket:

