

# MV-CS016-10GM/GC

1.6 MP 1/2.9" CMOS GigE Area Scan Camera



GEN*i*CAM

GigE  
VISION

## Introduction

MV-CS016-10GM/GC camera adopts Sony® IMX296 sensor to provide high-quality image. It uses GigE interface to transmit non-compressed images in real time, and its max. frame rate can reach 65.2 fps in full resolution.

## Key Feature

- Adopts brand new design to reduce power consumption.
- Compact design with mounting holes on panels for flexible mounting from 4 sides.
- Supports noise reduction and color correction matrix function.
- Supports auto or manual adjustment for gain, exposure time, LUT, Gamma correction, white balance, etc.
- Adopts GigE interface and max. transmission distance of 100 meters without relay.
- Compatible with GigE Vision V2.0 Protocol, GenICam Standard, and third-party software based on the protocol and standard.

## Available Model

- Mono camera: MV-CS016-10GM
- Color camera: MV-CS016-10GC

## Applicable Industry

SMT/ PCB AOI, consumer electronics, electrical semiconductor, image measuring, etc.

## Sensor Quantum Efficiency

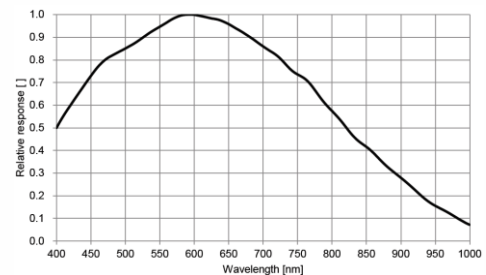

MV-CS016-10GM

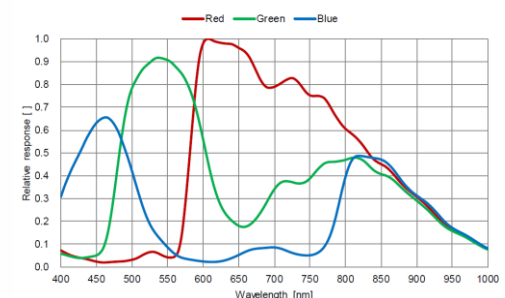

MV-CS016-10GC

## Dimension

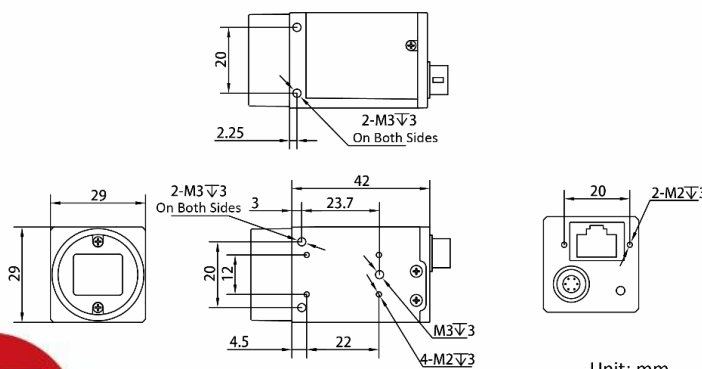

## Specification

Model	MV-CS016-10GM	MV-CS016-10GC
<b>Camera</b>		
Sensor type	CMOS, global shutter	
Sensor model	Sony® IMX296	
Pixel size	3.45 μm × 3.45 μm	
Sensor size	1/2.9"	
Resolution	1440 × 1080	
Max. frame rate	65.2 fps @1440 × 1080	
Dynamic range	74 dB	
SNR	41 dB	
Gain	0 dB to 24 dB	
Exposure time	UltraShort exposure mode: 1 μs to 14 μs	
	Standard exposure mode: 15 μs to 10 sec	
Exposure mode	Off/Once/Continuous exposure mode	
Mono/color	Mono	Color
Pixel format	Mono 8/10/10p/12/12p	
	Mono 8/10/12, Bayer RG 8/10/10p/12/12p, YUV422Packed, YUV422_YUYV_Packed, RGB 8, BGR 8	
Binning	Supports 1 × 1, 1 × 2, 1 × 4, 2 × 1, 2 × 2, 2 × 4, 4 × 1, 4 × 2, 4 × 4	
Decimation	Supports 1 × 1, 1 × 2, 1 × 4, 2 × 1, 2 × 2, 2 × 4, 4 × 1, 4 × 2, 4 × 4	
Reverse image	Supports horizontal and vertical reverse image output	
<b>Electrical features</b>		
Data interface	Gigabit Ethernet, compatible with Fast Ethernet	
Digital I/O	6-pin Hirose connector provides power and I/O, including opto-isolated input × 1 (Line 0), opto-isolated output × 1 (Line 1), bi-directional non-isolated I/O × 1 (Line 2).	
Power supply	9 VDC to 24 VDC, supports PoE	
Power consumption	Typ. 2.4 W@12 VDC	Typ. 2.5 W@12 VDC
<b>Mechanical</b>		
Lens mount	C-mount	
Dimension	29 mm × 29 mm × 42 mm (1.1" × 1.1" × 1.2")	
Weight	Approx. 100 g (0.22 lb.)	
Ingress protection	IP40 (under proper lens installation and wiring)	
Temperature	Working temperature: -30 °C to 60 °C (-22 °F to 140 °F)	
	Storage temperature: -30 °C to 70 °C (-22 °F to 158 °F)	
Humidity	20% to 95% RH, non-condensing	
<b>General</b>		
Client software	MVS or third-party software meeting with GigE Vision Protocol	
Operating system	32/64-bit Windows XP/7/10, 32/64-bit Linux and 64-bit MacOS	
Compatibility	GigE Vision V2.0, GenICam	
Certification	CE, RoHS, KC	

# HIKROBOT

Hangzhou Hikrobot Co., Ltd.  
en.hikrobotics.com

© Hangzhou Hikrobot Co., Ltd. All Rights Reserved.

Hangzhou Hikrobot does not tolerate any infringement. Any organization or individual may not imitate or reproduce in whole or in part of the content. The data herein is based on Hikrobot's internal evaluation. Actual data may vary depending on specific configuration and operating condition. The information herein is subject to change without notice. All the content has been checked conscientiously. Nevertheless, Hikrobot shall not be liable to damages resulting from errors, inconsistencies or omissions.