

MV-CB004-10GM/C

0.4 MP 1/2.9" CMOS GigE Board Level Camera



GEN*i*CAM

GIG*E* VISION

Introduction

MV-CB004-10GM/C camera adopts Sony® IMX297 sensor to provide high-quality images. It uses GigE interface to transmit images in real time, and its max. frame rate can reach 125.2 fps in full resolution. The camera is small in size, which can meet different spatial requirements.

Key Feature

- Supports auto or manual adjustment of gain, exposure time, white balance, manual adjustment of Gamma correction, LUT, Binning, etc.
- Adopts noise reduction function to provide high-quality images.
- Adopts GigE interface and max. transmission distance of 100 meters without relay.
- Compatible with GigE Vision V2.0 Protocol, GenCam Standard, and third-party software based on the protocol and standard.

Applicable Industry

Electronic semiconductor, factory automation, logistics, bottle detection, medicine packing, etc.

Available Model

- Mono camera with M12-mount: MV-CB004-10GM-S
- Color camera with M12-mount: MV-CB004-10GC-S
- Mono camera with C-mount: MV-CB004-10GM-C
- Color camera with C-mount: MV-CB004-10GC-C

Sensor Quantum Efficiency

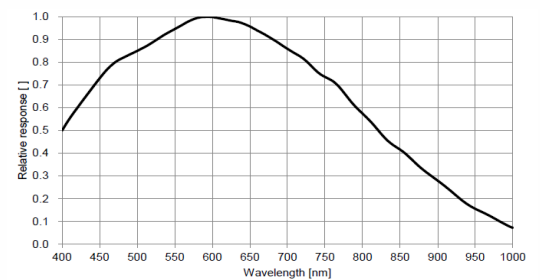

MV-CB004-10GM

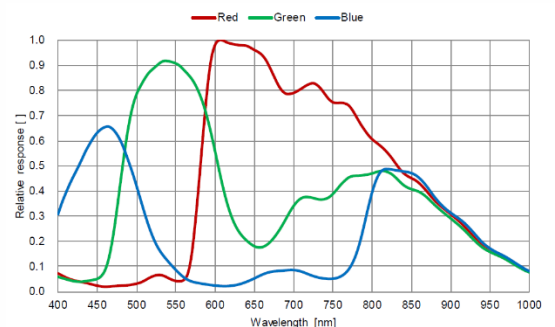

MV-CB004-10GC



Specification

Model	MV-CB004-10GM	MV-CB004-10GC
Camera		
Sensor type	CMOS, global shutter	
Sensor model	Sony® IMX297	
Pixel size	6.9 μm × 6.9 μm	
Sensor size	1/2.9"	
Resolution	720 × 540	
Max. frame rate	125.2 fps @720 × 540	
Dynamic range	74 dB	
SNR	41 dB	
Gain	0 dB to 24 dB	
Exposure time	UltraShort exposure mode: 1 μs to 14 μs	
	Standard exposure mode: 15 μs to 10 sec	
Exposure mode	Off/Once/Continuous exposure mode	
Mono/color	Mono	Color
Pixel format	Mono 8/10/10p/12/12p	Mono 8/10/12, Bayer RG 8/10/10p/12/12p, YUV422Packed, YUV422_YUYV_Packed, RGB 8, BGR 8
Binning	Supports 1 × 1, 1 × 2, 1 × 4, 2 × 1, 2 × 2, 2 × 4, 4 × 1, 4 × 2, 4 × 4	
Decimation	Supports 1 × 1, 1 × 2, 1 × 4, 2 × 1, 2 × 2, 2 × 4, 4 × 1, 4 × 2, 4 × 4	
Reverse image	Supports horizontal and vertical reverse image output	
Electrical features		
Data interface	Gigabit Ethernet, compatible with Fast Ethernet	
Digital I/O	6-pin connector provides power and I/O, including non-isolated input × 1 (Line 0), non-isolated output × 1 (Line 1), and bi-directional non-isolated I/O × 1 (Line 2).	
Power supply	9 VDC to 24 VDC, supports PoE	
Power consumption	Typ. 2.5 W@12 VDC	Typ. 2.6 W@12 VDC
Mechanical		
Lens mount	C-mount or M12-mount	
Dimension	29 mm × 29 mm × 30.2 mm (1.1" × 1.1" × 1.2")	
Weight	Approx. 45 g (0.1 lb.)	
Temperature	Working temperature: 0 °C to 50 °C (32 °F to 122 °F)	
	Storage temperature: -30 °C to 70 °C (-22 °F to 158 °F)	
Humidity	20% to 80% RH, non-condensing	
General		
Client software	MVS or third-party software meeting with GigE Vision Protocol	
Operating system	32/64-bit Windows XP/7/10, 32/64-bit Linux and 64-bit MacOS	
Compatibility	GigE Vision V2.0, GenICam	
Certification	CE, FCC, RoHS, KC	

Dimension

Camera with C-mount:

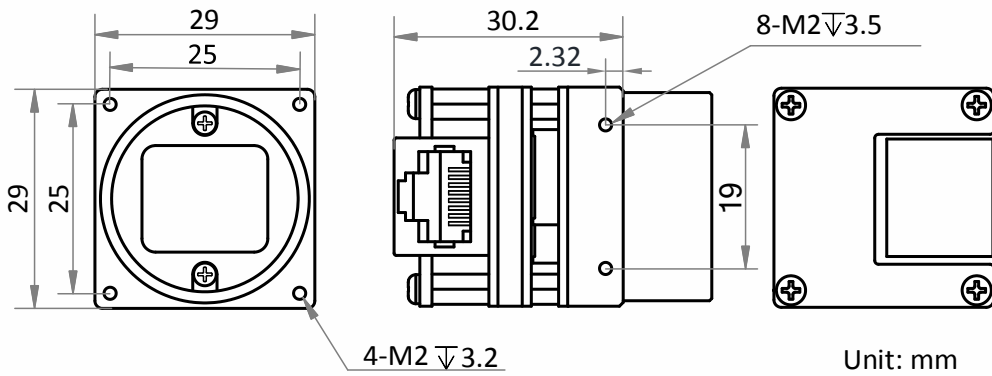

Camera with M12-mount:

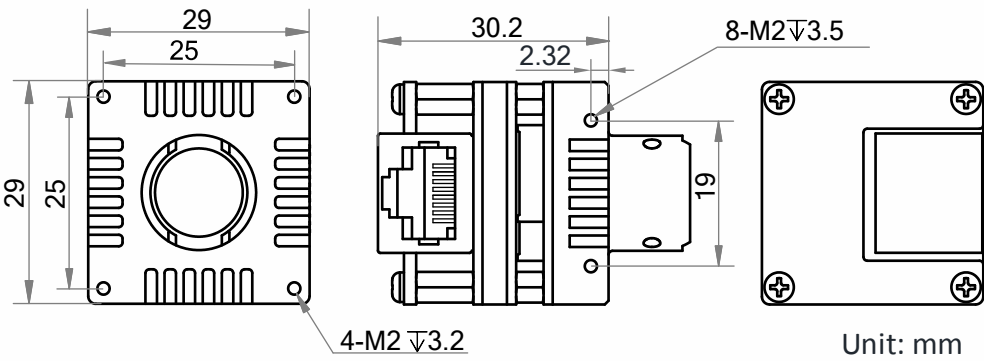

HIKROBOT

Hangzhou Hikrobot Technology Co., Ltd.
No.399 Danfeng Road, Binjiang District, Hangzhou 310051, China.
en.hikrobotics.com

Copyright Hikrobot

Hangzhou Hikrobot Technology Co., Ltd. All Rights Reserved. Hangzhou Hikrobot Technology does not tolerate any infringement. Any organization or individual may not imitate or reproduce in whole or in part of the content. The data herein is based on Hikrobot's internal evaluation. Actual data may vary depending on specific configuration and operating condition. The information herein is subject to change without notice. All the content has been checked conscientiously. Nevertheless, Hikrobot shall not be liable to damages resulting from errors, inconsistencies or omissions.